

A 1 1/2" & 2" METER VAULT
- N.T.S.

B SECTION
- N.T.S.

NOTES:

1. ALL WORK MUST BE INSPECTED BY DRAPER IRRIGATION COMPANY PRIOR TO BACKFILL.
2. BYPASS VALVE TO BE LEFT IN THE OFF POSITION & SEALED BY DRAPER IRRIGATION COMPANY.
3. METER SUPPLIED BY DRAPER IRRIGATION COMPANY.
4. SETTER SPACING REQUIREMENTS
1.5" METER = 13.25" SPACING
2" METER = 17.25" SPACING

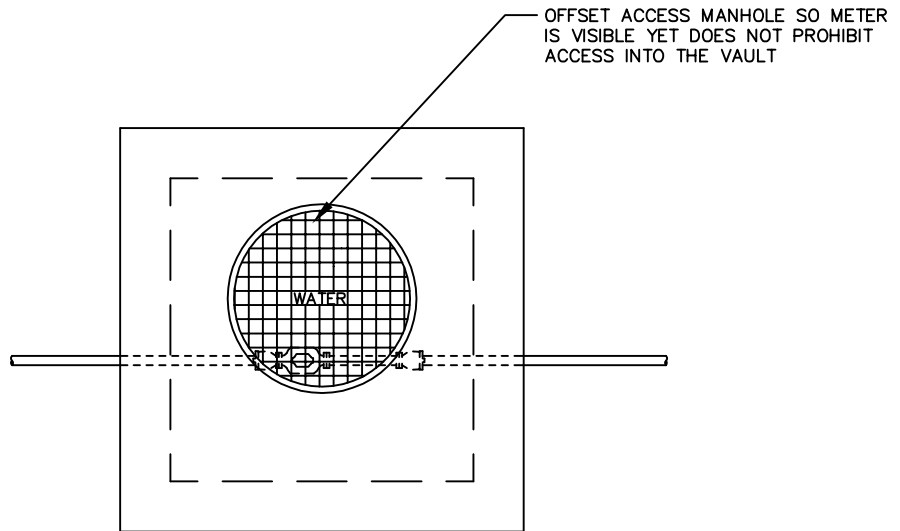

C DECK SLAB
- PLAN VIEW

